

Automotive Flasher Modules

There are four types of flashers for the Automotive Market. They are classified by function as: 1) Turn Signal; 2) Hazard Warning; 3) Combination, Turn Signal/Hazard Warning; 4) Alternating Flashers.

Turn Signal Flasher

Definition: The turn signal flasher is a device installed in a vehicle lighting system with the primary function of causing the turn signal lamps to flash when the turn signal switch is activated to left or right. The secondary functions may include the visible pilot indicators for the turn signal system, an audible signal to indicate when the flasher is operating and a turn signal lamp outage indicator.

Hazard Warning Flasher

Definition: The hazard warning flasher is a device installed in a vehicle lighting system with the primary function of causing the left and right turn signal lamps to flash when the hazard warning switch is activated. Secondary functions may include visible pilot indicators for the hazard system and an audible signal to indicate when the flasher is operating.

Combination, Turn Signal & Hazard Warning Flasher

Definition: The combination flasher is a device which combines the functions of a turn signal flasher and hazard warning flasher into one package.

Alternating Flasher

Definition: The alternating flasher is a device installed in an emergency vehicle lighting system which has the primary function of causing warning lamps, head lamps, etc. to flash alternately when the system is activated. Secondary functions may include visible pilot indicators for the warning system and an audible signal to indicate when the flasher is operating. This type of flasher is typically used on emergency vehicles and school buses.

There are currently three different technologies utilized in automotive flasher designs.

Bimetal Flashers

The bimetal flashers are the lowest cost with a shorter life expectancy than hybrid or solid state flashers. The operation of this flasher is current sensitive which means that the flasher will stop flashing when one of the light bulbs is out and that it will flash at a faster rate when adding additional load such as occurs when a trailer is added. The operating voltage and temperature range of bimetal flashers are more limited as these parameters also effect flash rate.

Hybrid Flashers

The hybrid flashers have an electronic flasher control circuit to operate the internal electromechanical relay. This type has a very stable electronic timing circuitry that enables a wide operating voltage and temperature range with a reasonable cost. The life expectancy is considerably longer compared to bimetal units and is dependent on the load and relay used internally for switching the load. The hybrid flasher has lamp outage sensing causing the flash rate to double when a bulb is out.

Solid State Flashers

The solid state flashers have an internal electronic circuit for timing and solid state power output devices for load switching. Life expectancy is longer than other flashers because there are no moving parts for mechanical breakdown. The application for solid state product must be carefully selected for over load and temperature conditions; solid state products can be destroyed when misapplied. Bimetal and hybrid flashers take more abuse without significant loss of useful life. Heatsinking is a necessity for solid state devices for high power switching. For this reason the size of this flasher may be larger than other flasher types. The biggest disadvantage of solid state is the higher price. Solid state flashers also have a lamp outage sensing feature similar to the hybrid flashers.

Principle of Flasher Operations

Bimetal Flasher

Bimetal flashers are primarily composed of a "bimetal" element with

contacts mounted to it. The bimetal element is a sandwich of two different metals that distorts with temperature changes. The turn signal lamp current is passed through the bimetal element and causes heating. When the element is hot enough, the bimetal distorts, opening the contacts and turning off the lamps. After the bimetal cools, it returns to the original shape, closing the contacts and turning the lamps on again. This sequence is repeated until the load is removed. Lamp outage is indicated by the lamp remaining on due to insufficient heat for the off-state distortion to occur.

Hybrid Flasher

Hybrid flashers offer the best balance in cost, size and performance for most applications. Potter & Brumfield's hybrid design exceeds all industry standards such as Federal Motor Vehicle Safety Standard 108 (FMVSS 108) and Society of Automotive Engineers (SAE) standards.

Below you will find a typical hybrid flasher circuit and circuit description.

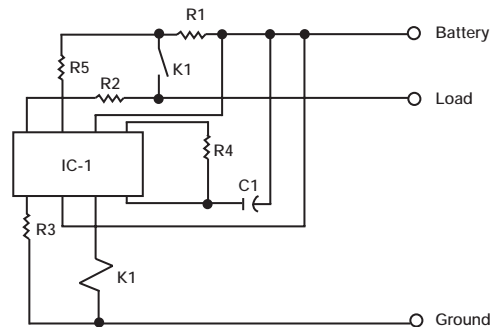

Figure 1. Schematic for Dual Function Hybrid Flasher

Circuit Description

Referring to the schematic above, IC-1 is an integrated circuit designed specifically for the application. It contains a trigger circuit, an oscillator, a lamp fault detector, a reference voltage regulator, an RF filter, transient protection, an on-chip relay driver and protection circuitry.

The trigger circuit detects a momentary ground path through resistor R2. An external switch (typically the turn signal switch) makes connection through the light bulb filaments to the system ground, which immediately causes drive voltage to appear across the relay coil. The detected (grounded) condition is then internally latched and not sampled again until a short time (milliseconds) after the coil voltage is electronically removed (during the last half of the flashing cycle). If there are NO good filaments, then the flasher unit will not start at all because no ground path will be detected.

Start Time

The oscillator circuit consists of capacitor C1, resistor R1 and some internal circuitry in the IC. The "start time" on the flasher assembly is controlled by the time constant ($R1 \times C1$) of the first discharge of C1, until the lower of two internal thresholds is reached. After that, both the "on time" and the "off time" are controlled by the individual thresholds in the controlling IC.

Lamp Outage Sensing

The lamp fault detector is designed to sense whether there is adequate current being demanded by the combined light bulb loads, and, if not, the flasher will dramatically increase the flash frequency by a typical ratio of 2:1.

The method of sensing the above described "low load" condition involves a current sensing circuit which monitors the voltage drop across a very low ohmic value resistor. There is an RF filter (internal to the IC) which is intended to filter out effects of radio frequency interference, and also reduces the effects of transients on the IC. There is also an internal reference voltage which is compared against the voltage drop across the

sense resistor, and the result of that comparison determines if the oscillator will run at "normal" rate or at "double rate" for bulb outage detection.

Transient Protection

Transient protection is an integral part of the control IC. The transient protection consists of clamp diodes which limit the voltage on the protected pin. This will protect the IC from damage due to externally applied low energy transients.

Solid State Flasher

Solid state flashers are similar to the hybrid flashers with the exception that a solid state switch (e.g. MOSFET) is used for lamp switching in place of the electromechanical relay.

Application Classification

The flashers are classified by contact loads, such as 2 bulb, 3 bulb, 4 bulb and 5 bulb systems. It may be helpful if we explain what we mean by these different systems.

Turn Signal

If a unit is specified and marked "Turn Signal Flasher, 2 Bulb System," this means that it's function is turn signal flasher only and is designed for the 2 bulb system. The number of bulbs in the system is determined by the number of main signal lamps used in front and in the rear of the vehicle, (see Table 1 for contact load requirement for 2, 3, 4 and 5 lamp systems). A 2 bulb turn signal flasher has one bulb per side at the front of the vehicle and one bulb per side at the rear of the vehicle.

Turn Signal/Hazard Warning

If the application requires a turn signal and hazard warning flasher (sometimes called Combination Flasher) the unit will be specified "Turn Signal/Hazard Warning Flasher, 2/4 Lamp System." The terminology "2/4" will be interpreted as 2 bulbs used during turn signal mode and 4 bulbs used during hazard warning mode.

Typical application diagram for dual flashers.

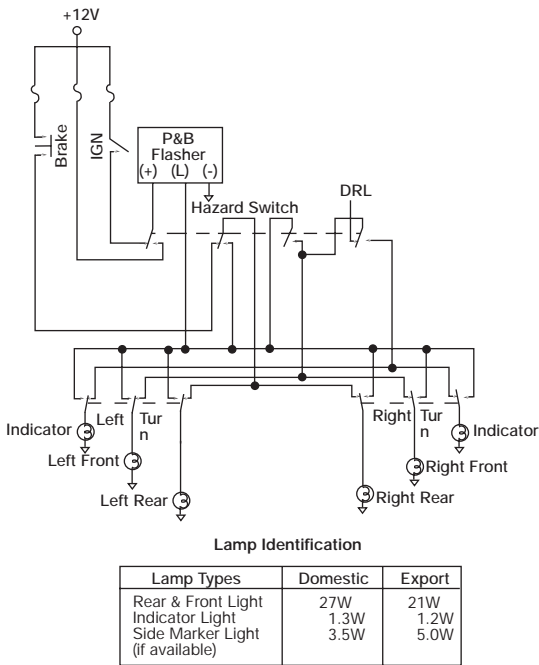

Figure 2. Typical application diagram for turn signal and hazard warning flashers wired for a 2 bulb system.

Product Specifications

I. Contact Load Requirements @ 12.8VDC

Turn Signal Mode

Loads System	European		U. S. A.			
	2 Lamp System	3 Lamp System	2 Lamp System	3 Lamp System	4 Lamp System	5 Lamp System
Rated Loads	2x21W +1x5W +1x1.2W	3x21W +1x5W +1x1.2W	2x27W +1x3.5W +1x1.3W	3x27W +1x3.5W +1x1.3W	4x27W +1x3.5W +1x1.3W	5x27W +1x3.5W +1x1.3W
Outage Loads	1x21W +1x5W +1x1.2W	2x21W +1x5W +1x1.2W	1x27W +1x3.5W +1x1.3W	2x27W +1x3.5W +1x1.3W	3x27W +1x3.5W +1x1.3W	Not Applicable

Hazard Mode

Loads	European		U. S. A.			
	2 Lamp System	3 Lamp System	2 Lamp System	3 Lamp System	4 Lamp System	5 Lamp System
Rated Loads	4x21W +2x5W +2x1.2W	6x21W +2x5W +2x1.2W	4x27W +2x3.5W +2x1.3W	6x27W +2x3.5W +2x1.3W	8x27W +2x3.5W +2x1.3W	10x27W +2x3.5W +2x1.3W

Table 1. Contact Load Requirements for 2, 3, 4 and 5 bulb systems.

NOTE: 1.2W bulbs for European cars and 1.3W bulbs for USA cars are optional. Refer to factory for more information.

II. Flash Rate & Duty Cycle Specification

Flash Rate:

The flash rate is the number of cycles ("on" and "off" time) in one minute. Units may provide one or two flash rates depending on the intended function.

Turn Signal Mode				Hazard Mode	
Normal Signal		Outage Signal		Normal Signal	
FPM	Duty Cycle (%)	% Increase	Duty Cycle (%)	FPM	Duty Cycle (%)
70-110	35-55	80-200	35-55	70-110	35-55

Table 2. Flash Rate and Duty Cycle Data

Flash rate per minute (FPM) can be determined as follows:

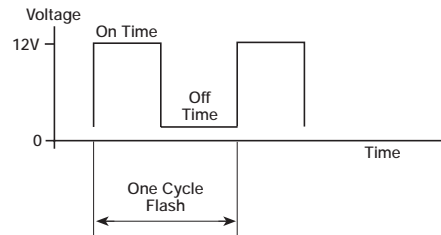

Figure 3. Flash Rate & Duty Cycle Wave Form

Our data indicates flash rate = 70 - 110 FPM. This means that one flash cycle as shown on Figure 3 has to be repeated 70 - 110 times in one minute.

Calculation:

$$\text{Flash Rate (FPM)} = \frac{60 \text{ seconds}}{\text{On Time} + \text{Off Time}}$$

Example: Measured On Time = .36 seconds
Off Time = .33 seconds

$$\text{Flash Rate (FPM)} = \frac{60 \text{ seconds}}{.69 \text{ seconds}} = 86.95 \text{ FPM}$$

Duty Cycle:

The duty cycle is the percent of "on" time in one complete cycle.

The formula below can be used to calculate duty cycle.

$$\text{Duty Cycle (\%)} = \frac{\text{On Time}}{\text{On Time} + \text{Off Time}}$$

Example: Refer to Figure 3 and use the same turn on and turn off time values in flash rate.

$$\begin{aligned} \text{Duty Cycle (\%)} &= \frac{0.36 \text{ seconds}}{0.36 + 0.33} \\ &= .52 \\ &= 52\% \end{aligned}$$

Lamp Outage Signal:

Flashers intended for turn signal operation provide a function for sensing low load current associated with one or more of the main lamps in the circuit being out. Solid state and hybrid flashers use electronic load sensing and indicate lamp outage as an 80-200% increase of flash rate. Bimetal flashers sense lamp outage directly. When one or more lamps are out, the circuit does not draw enough current to cause the bimetal to open the circuit. Therefore, lamp outage is indicated by a continuously on signal.

Note: Lamp outage sensing is provided on flashers with 2, 3 and 4 bulb systems during turn signal operation. FMVSS 108 requires hazard flashers to cycle at the normal rate with 2 bulbs flashing. A 2 bulb combination flasher will meet FMVSS requirements; however, combination flashers for 3 or more bulbs must disable the lamp outage detection when in hazard mode.

The 5 bulb flasher has no lamp outage sensing function in either turn signal or hazard warning modes. The 5 bulb flasher is designed to be used on wide body vehicles. FMVSS does not require lamp outage sensing on vehicles 80" or wider.

III. Operating Characteristics:

Nominal Voltage:	12 VDC system
Operating Voltage Range:	9 - 16 VDC
Device Voltage Drop:	Less than 0.400VDC at rated turn signal load. Less than 0.450VDC at rated hazard signal load.
Initial Turn-on Time:	Less than or equal to 50 msec.
Start Time:	Less than 1.0 sec per FMVSS 108
Sound Pressure Level:	Approx. 72 dbA at 1.0 meters

Table 3. Operate Data

Operating Voltage Range:

P&B hybrid flashers are designed for use in the vehicles with nominal 12 VDC systems. The system voltage is normally 12 to 14 VDC if the electrical system in the car is functioning properly. The voltage will be lower if the car is not running and the system is operating from battery voltage only. The voltage may be higher if the regulator is not functioning properly. Flashers are designed to operate from 9 VDC to 16 VDC.

Device Voltage Drop:

The device voltage drop is measured between (+) terminal and load terminal at the rated turn signal or hazard warning load. See Figure 2 for typical application diagram. Maximum device voltage drop is specified by FMVSS 108 and is intended to insure that lamps are provided with adequate voltage to be properly illuminated.

Initial Turn On Time:

The initial turn on time is the actual measured time. The turn on time of a normally closed type flasher (such as the alternating flasher which has NO and NC contacts) is the time to open the circuit after the voltage is applied. The turn on time of a normally open type of flasher (such as the hybrid flasher) is the time to close the circuit after the voltage is applied.

Start Time:

Federal Motor Vehicle Safety Standard 108 references the SAE J590 Turn Signal Flasher specification which describes start time as follows:

"The start time of a normally closed type flasher is the time to open the circuit after the voltage is applied. The start time of a normally open type of flasher is the time to complete one cycle (close the circuit/open the circuit) after the voltage is applied."

Sound Pressure Level (Audible Sound):

This requirement is limited to turn signal flashers or combination flashers operated in the turn signal mode. The purpose is to ensure that the vehicle operator will detect an audible sound during turn signal usage. Actual sound level of the flasher as applied within the vehicle is highly dependent on mounting method and location. Perceived sound level is also dependent on the ambient sound level within the vehicle associated with wind, road and engine noise.

IV. Environmental Specifications**Operating**

Ambient Temperature: -40°C to +85°C

Storage

Ambient Temperature

Range:

-40°C to +105°C

Shock:

20g, 10 millisecond, half sine wave pulse

Vibration:

10-40 Hz., 1.27 mm double amplitude

40-70 Hz., 5g's constant

70-100 Hz., 0.5 mm double amplitude

100-500 Hz., 10g's constant

Drop Test:

Capable of meeting performance specifications after a 1.0 meter drop onto concrete or steel anvil

Flammability:

UL 94VO external
UL94-HB (or better) internal parts
(meets FMVSS 302)

Table 4. Environmental Data

Because the functions are controlled by electronics, P&B hybrid flashers have a wide range of operating temperatures that meet the automotive industry requirements. The flash rate in hybrid flashers are relatively unaffected by temperature. In contrast bimetal flashers have a wide variation of flash rate with temperature and will flash very slowly or not at all under cold conditions. Solid state flashers will have difficulty operating at high ambient temperatures due to inability to adequately dissipate the heat generated in the solid state switching device.

Shock and vibration values shown in Table 4 are typical values that are specified by the major customers for body mounted components for on road operation.

V. MECHANICAL DATA

Termination:	0.250" (6.35mm) quick connect
Enclosures:	Dust Cover (Protects relay from environment)
Cover Retention:	50 pound (220 Newton) minimum
Weight:	1.3 oz (37 grams) approximately

Table 5. Mechanical Data